



OPERATING INSTRUCTIONS
LEHLE MONO VOLUME S





Dear Musician!

Thank you for purchasing your LEHLE MONO VOLUME S!

I have been building units that switch, split and route signals with no technical compromises and with maximum musical fidelity since 1999.

Your new LEHLE MONO VOLUME S comprises only the very best components. Every assembly of your LEHLE MONO VOLUME S has been made and tested in Germany.

Your LEHLE MONO VOLUME S is of extremely robust design and construction, to make sure that you get absolutely years and years of enjoyment from it. If you should nonetheless have a problem, or simply a question, just mail me or a member of the Lehle team at:

support@lehle.com

I wish you the very greatest pleasure and success using your LEHLE MONO VOLUME S!

A handwritten signature in blue ink that reads "Burkhard G. Lehle". The signature is stylized and cursive.

CONTENT

- 4 Introduction
- 6 Technical data
- 7 General description
- 11 Description of the presets
- 12 Calibration of the pedal range

- Typical uses of the LEHLE MONO VOLUME S
- 13 as a classic volume pedal
- 14 in a wet dry system
- 16 to blend in effects
- 18 in an amp's effects loop
- 19 as expression pedal and recording preamp

- 21 LEHLE MONO VOLUME S signal flow diagram

With the LEHLE MONO VOLUME S you get an active and wear-free volume pedal, which is lighter and smaller but not less efficient: Equipped with the proven and evolving magnet sensor VCA technology of the other LEHLE VOLUME pedals, you control the volume of your instrument precisely.

As it has no mechanical potentiometer, the typical noise, endlessly expensive repairs and complicated adjustment can be avoided.

Your foot is just moving the magnet, while the Hall-sensor measures the distance, with great precision and very fast. An ARM Cortex CPU processes the data of the sensor in a matching, musical taper and controls the VCA. Here, the signal path is always kept completely analogue – and in your hands.

Stability – both electronic and mechanical.

Over the entire control range the LEHLE MONO VOLUME S transmits the full sound spectrum of the connected sound source. The input and output im-

pedance always stays the same, ensuring that unlike with potentiometers, there will be no damping of higher frequencies.

The input voltage coming from your power supply (9 – 15 V) is internally rectified, then filtered, stabilized and transformed to 30 V, thus achieving a total dynamic range of 120 dB. The high-end preamp with discrete Class-A input stage brings every little sound nuance to life – your tone becomes touchable.

There are no initial difficulties with the LEHLE MONO VOLUME S:

Low-friction bearings of a high-performance polymer bed the shaft gently into the aluminium enclosure and reduce any mechanical stress towards zero – thus, it runs mechanically extremely smooth and steady. By means of an adjusting screw the tension of the pedal can be modified with great precision from feathery to Vintage Car.

In addition to the mains output, a second also buffered direct output is available: Without affecting the sound negatively, you can provide a signal to a tuner, to a DAW or even a second amp.

Zero to hundred or boost à la carte? The LEHLE MONO VOLUME S has a boost available, which can deliver up to +12 dB more gain with a little extra emphasis (push) in the toe position.

When and how?

By means of using a little button you can recall presets: 0 dB, +5 dB or +10 dB. The last preset is the chef's speciality and remains an audiophile surprise.

The USB-C socket provides the functionality to calibrate, program and update the LEHLE MONO VOLUME S – by the way it sends MIDI data to your DAW or amp simulation of your choice.

Compared to the LEHLE MONO VOLUME we were able to reduce the weight by 50 % and the size by 35 % – with the same rugged stability and yet more dynamic. It's even 2 cm flatter, however the pedal range stays the same – just as comfortable and responsive as the larger models.

This is the LEHLE MONO VOLUME S: more volume – but half the size.



TECHNICAL DATA

Weight	766 g
Length	200 mm
Width	90 mm
Overall height	47 mm
Supply voltage	9 - 15 V DC
Current consumption	150 mA
Frequency range	35 Hz - 125 kHz (-3 / +0.4 dB)
THD	< 0.05 % at 1 kHz -10 dBu
Impedance input	2 M Ω
Impedance output	500 Ω
Level noise floor	-105 dBu (A-weighted)
Max. level	4.5 V RMS 15.5 dBu
Max. gain	12 dB

GENERAL DESCRIPTION

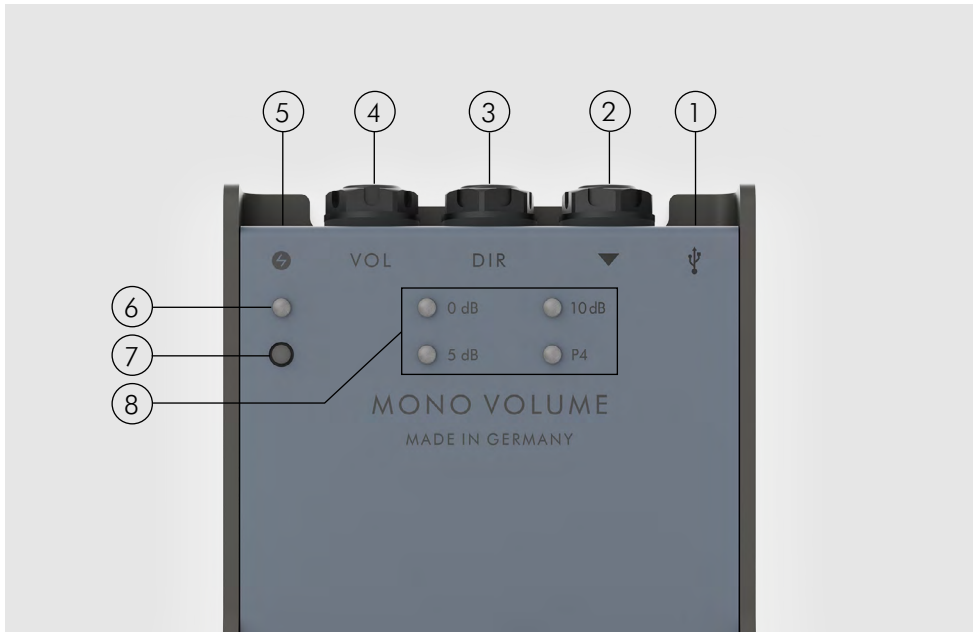

1. USB-C SOCKET

By means of this socket you can use the LEHLE MONO VOLUME S as a MIDI-USB expression pedal, supply it with power and update the firmware.



2. INPUT SOCKET

Connect your instrument here.



The input of the LEHLE MONO VOLUME S processes signals of electric and acoustic stringed instruments, as

guitars and basses, steel string and nylon string acoustics and acoustic string instruments of all kinds (such as violins with pickup systems). The input impedance of the LEHLE MONO VOLUME S is approx. 2 MOhm.

It doesn't matter if the connected signal has high or low impedance, or if it comes from a passive or an active pickup system. This means you can connect even synthesizers, keyboards or the send of your amp's effects loop.

3. DIR SOCKET

DIR

Connect a tuner or a second amp here.

The input signal is mirrored to this output with exactly the same level (unity gain). The DIR Out is buffered, which means you can connect both high and low impedance inputs to the DIR Out without influencing the sound of the input signal. If you are using a tuner, you can mute the VOL out (4) if the rocker is in heel position, so the DIR Out will provide a signal only.

4. VOL SOCKET

VOL

Connect your target device here.

For instance, this would be an amplifier, an effects pedal, a mixing desk, a stage box or an audio interface. This output, like the DIR output (3), is low impedance too, and does not change its impedance when the volume is altered via the volume pedal. Thus the sound stays always the same – independent of the volume.

5. EXTERNAL POWER SUPPLY



Connect a power supply with a voltage of 9 – 15 V.

In order that the LEHLE MONO VOLUME S can work flawlessly, it needs a current supply. This should supply a minimum of 9 V and a maximum of 15 V. Polarity is of no importance. To guarantee trouble-free operation the supplied voltage is in-

ternally rectified, filtered, stabilized and then transformed to 30 V headroom. In order to avoid noise it's recommendable to use a single power supply or an output of a multi power supply offering galvanically isolated outputs for the LEHLE MONO VOLUME S.

If the LEHLE MONO VOLUME S is connected to a computer via a USB cable to use it as MIDI-USB expression pedal or to update the firmware, you don't need an external power supply. However for the standard operation with connected sockets (2, 3 and 4) it's better to use its own power supply.

6. LED OF THE POWER SOCKET

This LED shows that your pedal is active.

Congratulations: The white LED shows you that the LEHLE MONO VOLUME S has started correctly and is active.

If you move the rocker of the pedal, a blue LED instead of the white LED indicates that you are changing the volume at the socket VOL (4), resp. that you are sending MIDI data if it's used as an expression pedal with your computer.

7. FUNCTION BUTTON

Button with multiple functions.

First of all the FUNCTION BUTTON acts to recall the presets of the pedal. By means of pushing the button several times, you are toggling between them,

shown by the FUNCTION LEDs (8). You can expect different boost stages as well as an individual preset. What exactly (you can expect) can be looked up in the chapter [“DESCRIPTION OF THE PRESETS” on page 11.](#)

The FUNCTION BUTTON is also used to calibrate the pedal. You can read how this is done in the chapter [“CALIBRATION OF THE PEDAL RANGE” on page 12.](#)

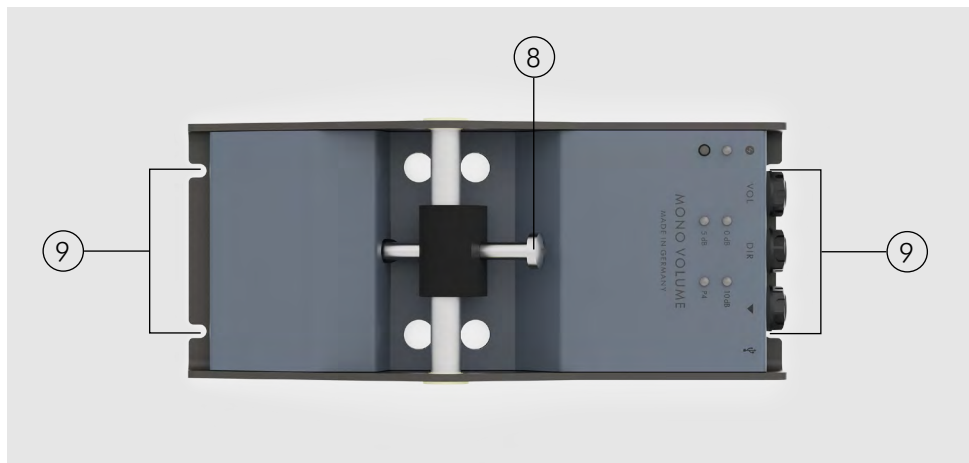

8. PEDAL FEEL

Turn this screw to adjust the feel of the pedal.

If you turn this screw clockwise, you tighten the brake. This way the pedal feel of the LEHLE MONO VOLUME S will be heavier.

Turning the screw counterclockwise diminishes the resistance when pressing and gives the rocker a lighter feel.

9. BASE AND FIXING

If needed, you can mount the LEHLE MONO VOLUME S to a plate such as a pedalboard.

The LEHLE MONO VOLUME S can easily be mounted to a plate using the prepared fixing system of the pedal. You need 4 screws (4.2x13) and 4 M4 washers.

First, we recommend that you pull out the rubber feet on the bottom.

Place the pedal without the rubber feet in the position where you want to attach it to the board. Use a fine-point pen or a sharp pencil to sketch the subsequent screw holes through the 4 mounting holes onto the base plate. Now drill at the site of the later screw holes a hole with a diameter of approximately 2.5 mm (1/10 inch). Then turn in two of the

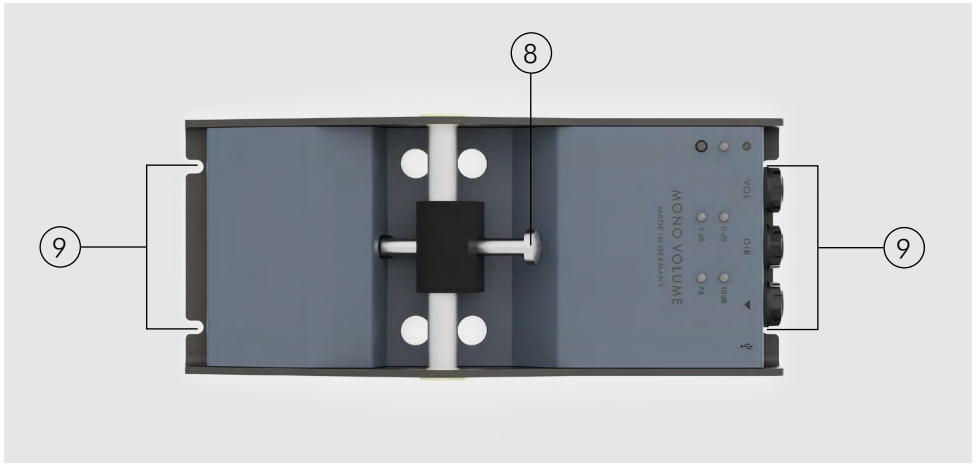

four screws together with the washers just halfway.

Slowly slide the LEHLE MONO VOLUME S with the holes under the screw heads of the screws already screwed in. Make sure that the washers are placed between the bottom plate of the LEHLE MONO VOLUME S and the screw head to protect the paint.

Now you can turn in the remaining two screws and spacers through the other two mounting holes. Tighten those screws only slightly, then fix the screws you first turned in. This type of mounting is extremely stable and can also be easily removed.

For flexible solutions we recommend using 3M Dual Lock™ instead of velcro for stability.

If you are using the velcro / Dual Lock™ method, please make a note of the serial number from the bottom of the pedal before you cover it, in case you have a support question for us later and don't fancy dismantling your board!



You can find replacement feet, Screw- and 3M Dual Lock™ sets at www.lehle-components.com

DESCRIPTION OF THE PRESETS

By using the FUNCTION BUTTON (7) you can recall the presets.



If you are in heel position, the pedal is at -95 dB, so virtually muted. This applies for every preset.

However in heel position you can expect this:

0 dB: If the rocker is in toe position, your input signal is at the VOL output (4) unaltered with unity gain.

5 dB: If the rocker is in toe position, your input signal is at the VOL output (4) with a boost of + 5 dB.

10 dB: If the rocker is in toe position, your input signal is at the VOL output (4) with a boost of + 10 dB.

P4: This is the preset 4. It's the chef's speciality and remains an audiophile surprise.

P4.1: This preset can be reached if you press the FUNCTION BUTTON (7) once again. The corresponding LED starts flashing.

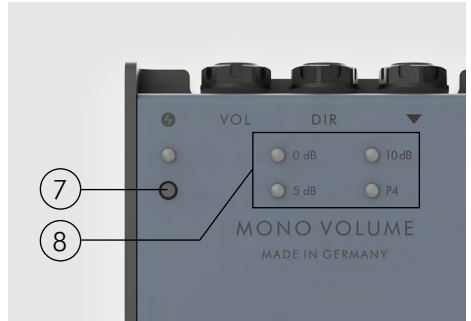

If it flashes slowly, your input signal is at the VOL output (4) unaltered with unity gain.

If you give the rocker in toe position a little extra kick, like you would hit a foot switch, the LED starts flashing fast and the boost with +12 dB is activated. Give the rocker a little kick again, you deactivate the boost and the LED flashes slowly again.



Depending on how clean, crunchy or distorted your following effects and amps are adjusted, the curve and boost of the presets might have different impact on them.

CALIBRATION OF THE PEDAL RANGE

In factory setting the pedal range of the LEHLE MONO VOLUME S is perfectly calibrated.

Normally it doesn't need a calibration again and is only necessary, if a mechanical component has been replaced.

The calibration does not change the minimum or maximum volume, too.

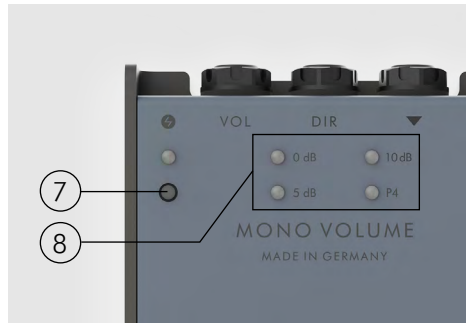

1. Press the FUNCTION BUTTON (7) for 5 seconds.

2. The FUNCTION LEDs (8) start flashing.

3. Move the rocker within 5 seconds (say "Lehle switcher" five times) to the most minimal heel position and then into the maximum toe position. The pedal learns these two positions and stores the values inside.

4. After the 5 seconds the FUNCTION LEDs stops flashing, go off and the calibration process is finished.

The LEHLE MONO VOLUME S reboots again.

If the LEDs flash in a row after the calibration, the process has been interrupted. The pedal will load the previous configuration at the next start. Please start the calibration process again.



TYPICAL USES

LEHLE MONO VOLUME S AS A CLASSIC VOLUME PEDAL

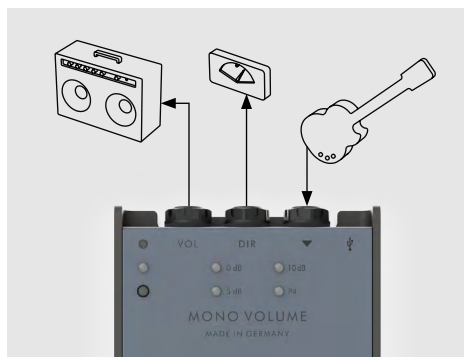

DEVICE CONNECTION

▼	Instrument
DIR	Tuner
VOL	Amplifier

The main purpose of the LEHLE MONO VOLUME S certainly is adjusting the volume of the signal on the VOL output (4). The DIR output (3) can be used for a tuner to silently tune the instrument in heel position of the rocker. Of course, this output can remain free.



How to do this:

1. Connect the cable of your instrument to the input socket (2).
2. Connect a tuner to the jack named DIR (3) or leave this input unconnected.
3. Connect the VOL jack (4) to the input of your amp.
4. Select with the FUNCTION BUTTON (7) one of the presets.
5. There you go!

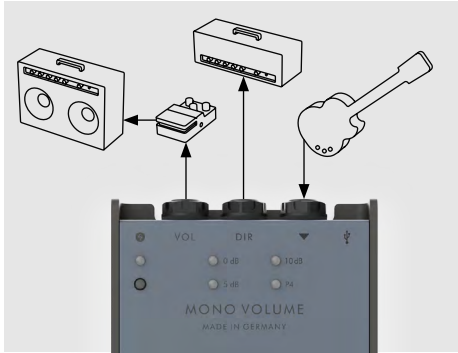
LEHLE MONO VOLUME S IN A WET DRY SYSTEM



DEVICE CONNECTION

-  Instrument
-  Amplifier 1
-  Wet effects chain

It's called a wet dry system if one amplifier gets the dry signal (without effects) and the other amplifier is wet (full range of effects). This way you won't lose the original signal, while on the second amp you can adjust the amount of effects. We recommend placing dynamic effects (compressor, overdrive) in-between your instrument and the LEHLE MONO VOLUME S so both amplifiers benefit from it and to send modulation and time-based effects (chorus, tremolo/vibrato, delay, reverb) only to one amplifier.

Place them in between the LEHLE MONO VOLUME S and the wet amp.

By means of the volume pedal you can adjust the amount of effects very dynamically and expressively, whereas the original signal stays always present and direct.

How to do this:

1. Connect your instrument or the output of your dynamic effects to the input socket (2) of the LEHLE MONO VOLUME S.
2. The amplifier getting the dry-signal needs to be connected to the DIR output (3).
3. Connect the VOL output (4) with the input of the effects chain representing the wet path.
4. Select with the FUNCTION BUTTON (7) one of the presets.
6. There you go!

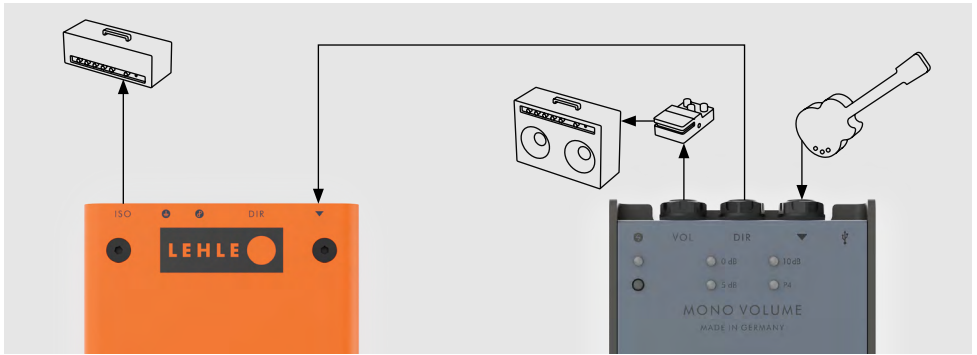

DEVICE CONNECTION LEHLE P-SPLIT III

- ▼ LEHLE MONO VOLUME S DIR
- DIR Not used
- ISO Amplifier 1

DEVICE CONNECTION LEHLE MONO VOLUME S

- ▼ Instrument
- DIR LEHLE P-SPLIT III
- VOL Wet effects chain

⚠ In case hum loops or phasing issues occur, we recommend placing a LEHLE P-SPLIT III in between the DIR output (3) and the dry amp.

How to do this:

1. Connect your instrument or the output of your dynamic effects to the input socket (2) of the LEHLE MONO VOLUME S.
2. Connect the DIR output (3) to the input of the LEHLE P-SPLIT III.
3. Connect the ISO output of the LEHLE P-SPLIT III with your amplifier 1.
4. Connect the VOL output (4) with the input of the effects chain representing the wet path.
5. Select with the FUNCTION BUTTON (7) one of the presets.

6. At the LEHLE P-SPLIT III press the ground and phase button until you get less noise and a direct and natural sound.
7. There you go!

Instead of the LEHLE P-SPLIT III you can use the LEHLE P-ISO, too. ✔
The connections are the same.



LEHLE MONO VOLUME S TO BLEND IN EFFECTS

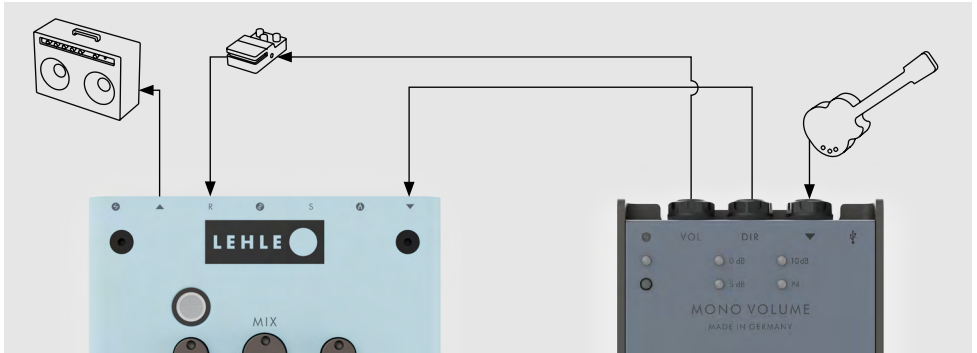

DEVICE CONNECTION LEHLE PARALLEL SW II

- ▼ LEHLE MONO VOLUME S DIR
- S Not used
- R Effects pedal output
- ▲ Amplifier

Do you want to control the amount of effects with the MONO VOLUME S, but play back the mix on one amplifier? Many effects sound much better when they are blended by a high-end mixing stage to the dry signal.

In combination with the LEHLE PARALLEL SW II you can realise this.

DEVICE CONNECTION LEHLE MONO VOLUME S

- ▼ Instrument
- DIR LEHLE PARALLEL SW II input
- VOL Effects pedal

How to do this:

1. Connect your instrument or the output of your last effects pedal to the input socket (2) of the LEHLE MONO VOLUME S.
2. The signal of the DIR output (3) needs to be sent to the input of the LEHLE PARALLEL SW II.
3. Connect the VOL output (4) to the input of the effects pedal you want to blend in.

4. The output of this effects pedal needs to be connected to the return socket of the LEHLE PARALLEL SW II.
5. The output of the LEHLE PARALLEL SW II is going to be connected with your amplifier or any other device.
6. Select with the FUNCTION BUTTON (7) one of the presets.
7. On the LEHLE PARALLEL SW II use the MIX control to set the balance between effects signal and dry signal.
8. If needed, press the phase switch at the LEHLE PARALLEL SW II, too.
9. There you go!



LEHLE PARALLEL SW II

LEHLE MONO VOLUME S IN AN AMP'S EFFECTS LOOP

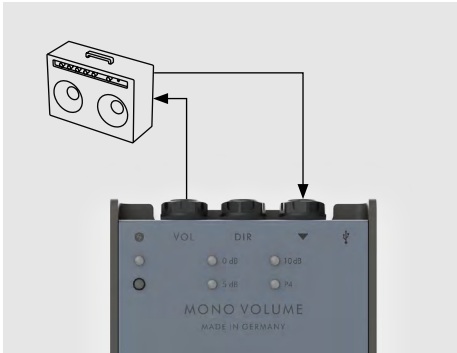

Thanks to the ability of handling high levels, you can of course use the LEHLE MONO VOLUME S in an amp's effects loop, too – as a master volume control or for that extra kick during your solo. Due to the volume pedal's placement after the preamp, the saturation/distortion won't be changed, just the volume. Effects can be added as well.

! If you want to have the volume attenuation going to mute, ensure your amp's effects loop is serial, respectively if it's a parallel loop it's set to 100 %.

DEVICE CONNECTION

- ▼ Amplifier send
- DIR Not used
- VOL Amplifier return



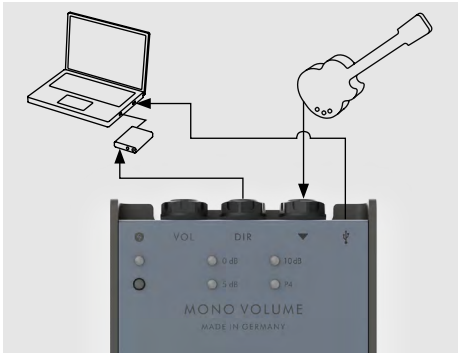

How to do this:

1. Take the FX send of your amp and connect it to the input socket (2) of the LEHLE MONO VOLUME S.
2. The DIR (3) stays unconnected.
3. The VOL output (4) needs to be connected back to your amplifier's FX return.
4. Select with the FUNCTION BUTTON (7) one of the presets.
5. Additionally you can place your effects before or after the LEHLE MONO VOLUME S.
6. There you go!

LEHLE MONO VOLUME S AS EXPRESSION PEDAL AND RECORDING PREAMP



DEVICE CONNECTION

-  Instrument
-  Audio interface
-  Not used
-  Computer

If the LEHLE MONO VOLUME S is connected to a computer, it's sending MIDI data to control software.

E.g. you can control effects or the volume of your digital amp simulation or manipulate the filter of a synthesizer in your DAW. As long as it receives MIDI and Control Change (CC), it's controllable.

The LEHLE MONO VOLUME S sends the control change command 11 on MIDI channel 1 by default.

At the same time you can use it as high-end recording preamp, too.

How to do this:

1. Connect the USB-C socket (1) with your computer and select in your software as the MIDI controller.
2. Connect your instrument to the input socket (2).
3. The DIR output (3) needs to be connected to the input of your audio interface.
4. The VOL (4) stays unconnected.
5. There you go!

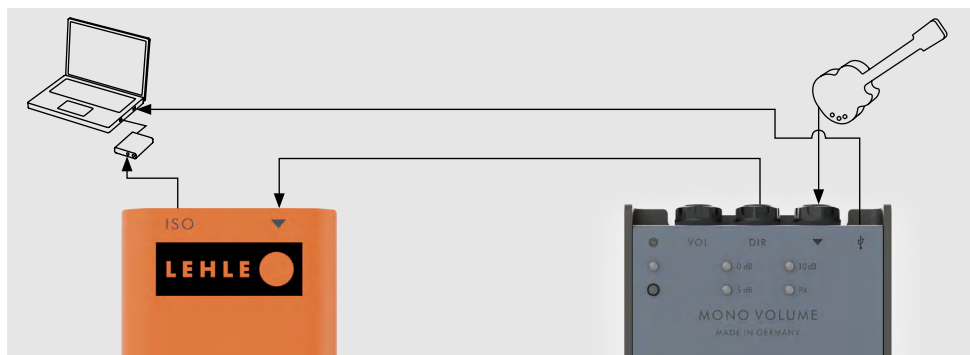

DEVICE CONNECTION LEHLE P-ISO

▼ LEHLE MONO VOLUME S DIR

ISO Audio Interface

DEVICE CONNECTION LEHLE MONO VOLUME S

▼ Instrument

DIR LEHLE P-ISO input

VOL Not used

USB Computer

If a hum- or buzz noise appears while both the audio cable and USB cable are connected, you are experiencing a ground loop between computer, audio interface and the LEHLE MONO VOLUME S.

ⓘ You can effectively eliminate it by using the LEHLE P-ISO in between the DIR output (3) and the audio interface and at the same time tap the signal via TRS jack and send it balanced to your audio interface. Alternatively, you can use the LEHLE P-SPLIT III. The connections are the same.

How to do this:

1. Connect the USB-C socket (1) with your computer and select in your software as the MIDI controller.
2. Connect your instrument to the input socket (2).
3. The DIR output (3) needs to be connected to the input of the LEHLE P-ISO.
4. Connect the ISO output of the LEHLE P-ISO with the input of your audio interface.
5. The VOL (4) stays unconnected.
6. There you go!

LEHLE MONO VOLUME 5 SIGNAL FLOW DIAGRAM

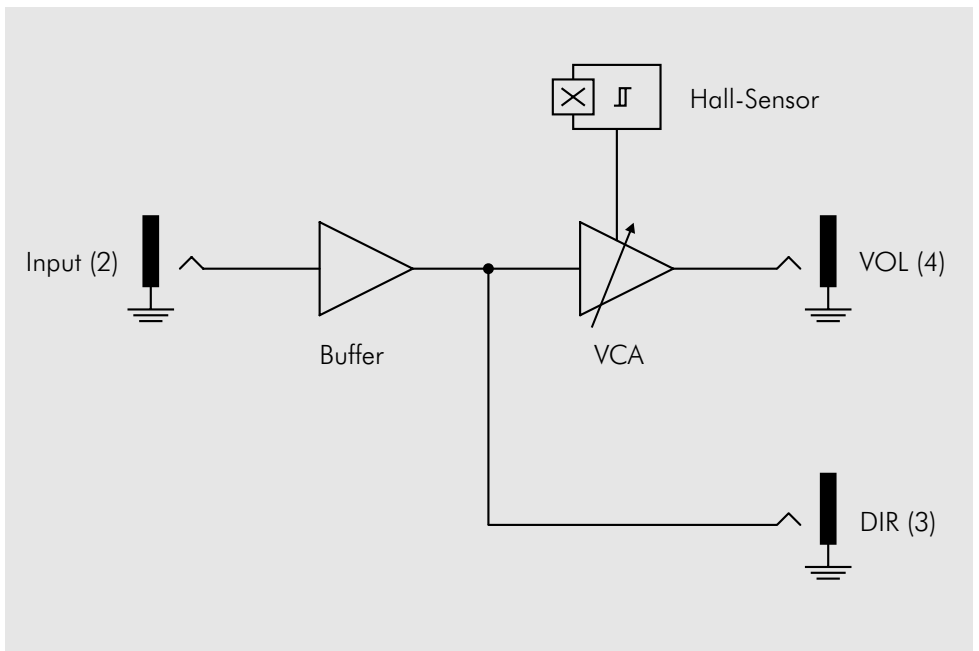



LEHLE GmbH · Grenzstrasse 153 · 46562 Voerde · Germany

www.lehle.com · support@lehle.com

LEHLE MONO VOLUME S Operating Instructions EN V1.1.0 · 2022-05-19

Copyright 2022 by LEHLE

